

# Horizontal Slider Secondary

Heavy Duty Section Guide



DURATION  
WINDOWS



# Contents



## Parts

Outer Frame	3
Panel Parts	4

## Sections

Top & Bottom Sections	5
2 Pane Slider	5
3 Pane Slider - Middle Fixed	6
3 Pane Slider - All Moving	6
4 Pane Slider - All Panes Moving	7

# Outer Frame

**HD103 - Bottom Outer Frame Track**

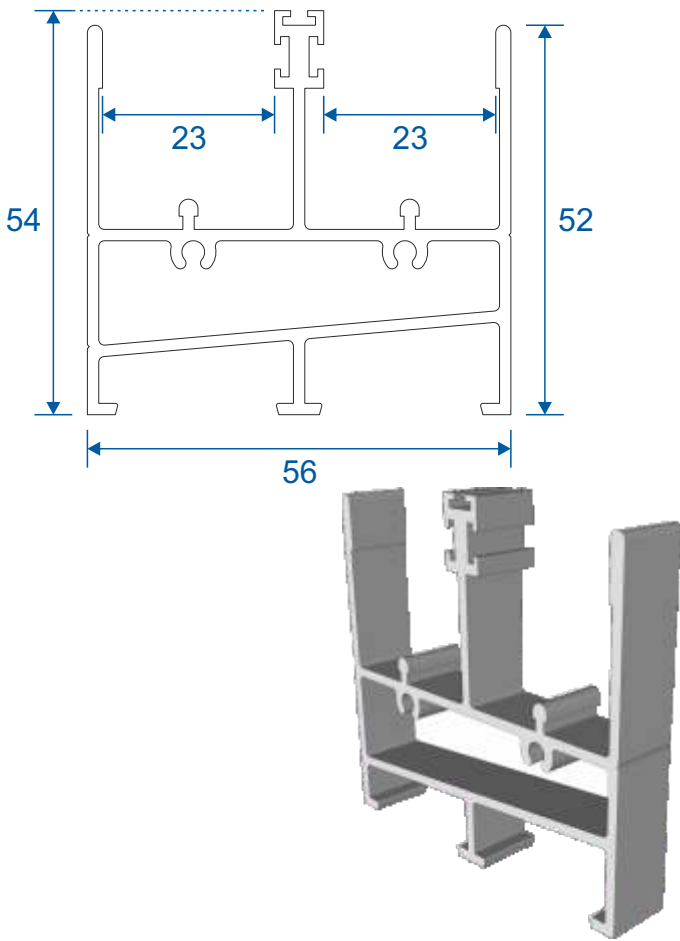

**HD97 - Outer Frame Sides (Jambs)**

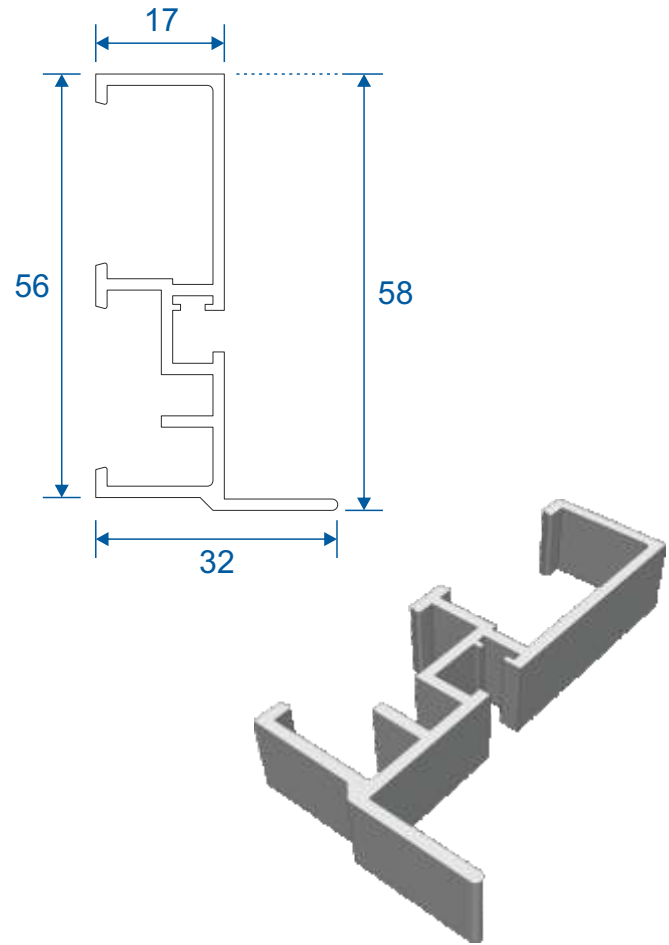

**HD98 - Top Outer Frame Track**

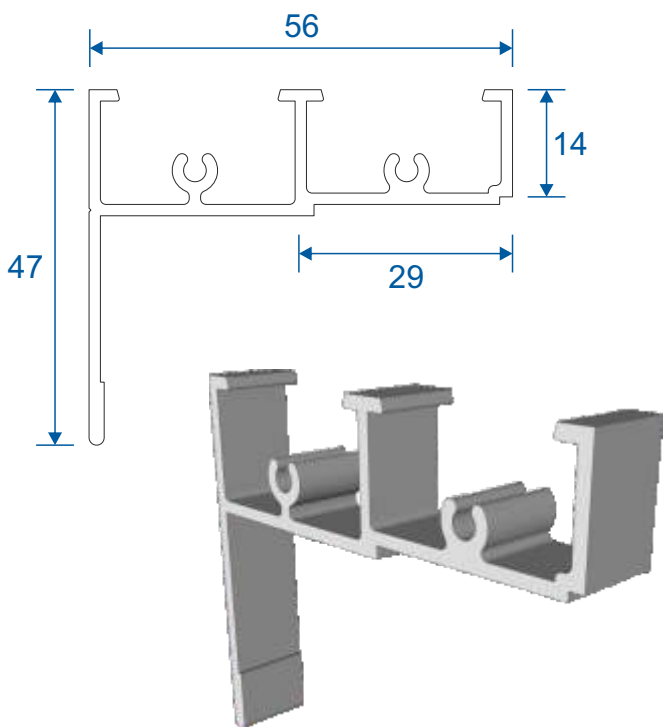

**HD99 - Outer Frame (Top Frame Adapter)**

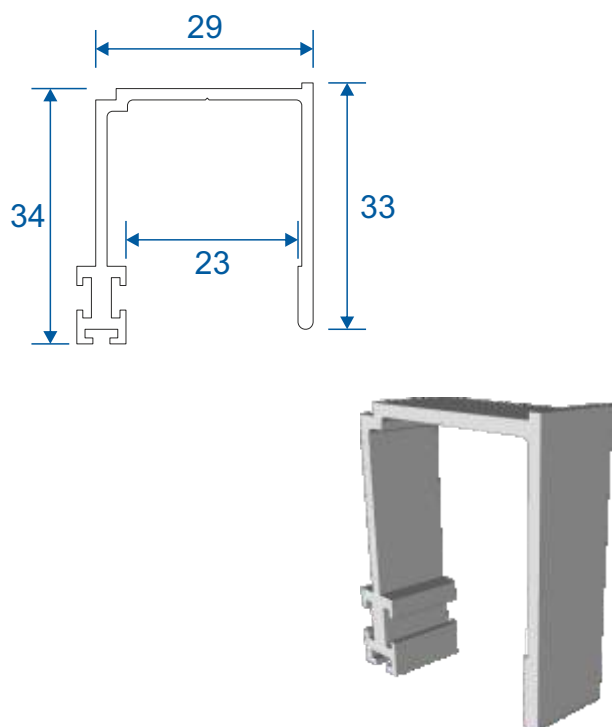

# Panel Parts

**HD46 - Panel Top & Bottom Rail**

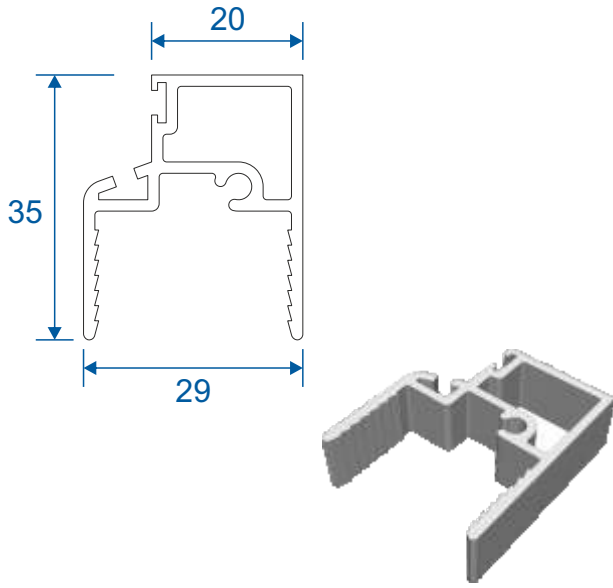

**HD47 - Panel Side Rails (Jamb)**

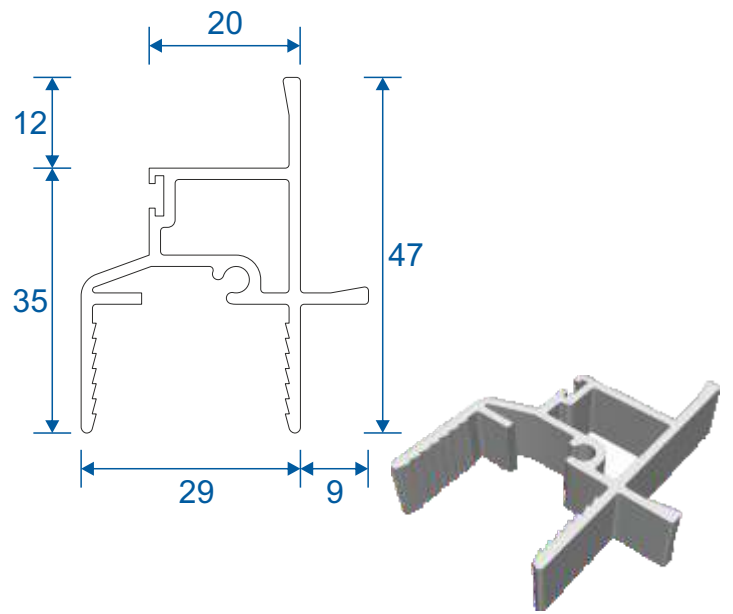

**HD45 - Panel Interlock**

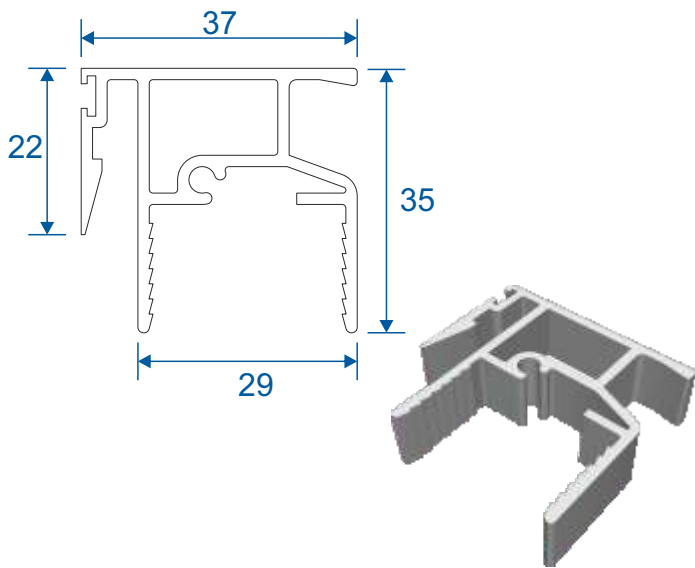

**HD45Rev - Panel Reverse Interlock**

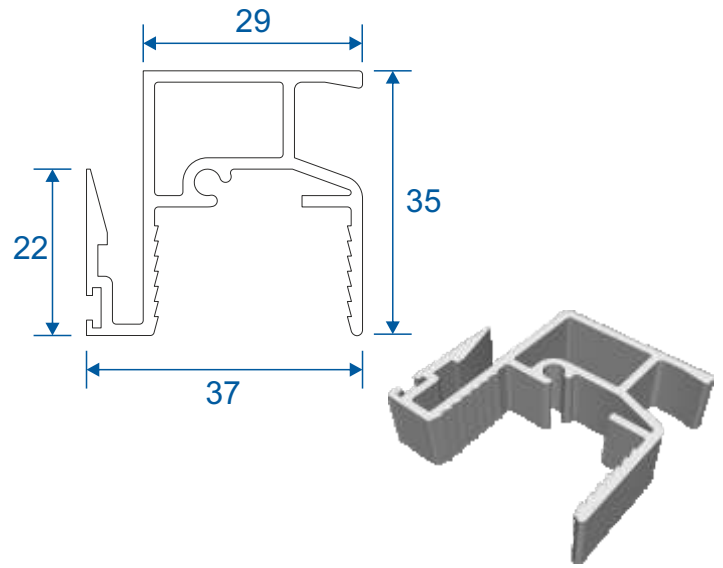

**HD102 - Odd Leg Extension**

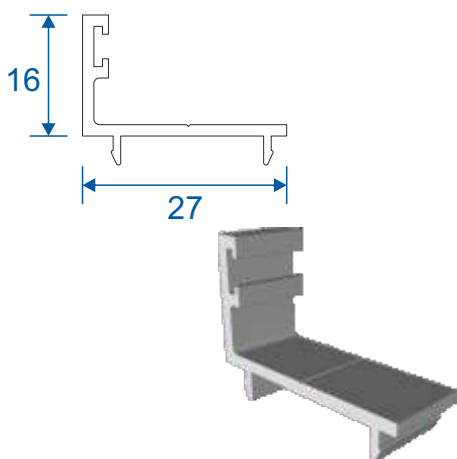

**HDL1 - Meeting Stile Adapter**

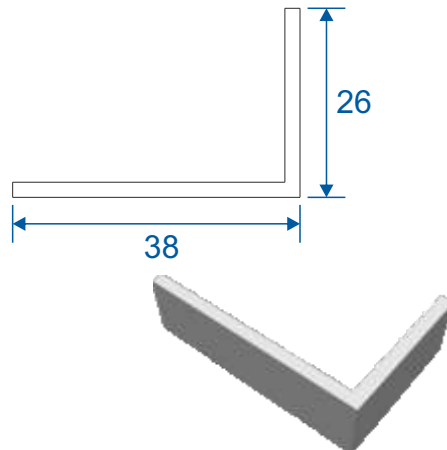

**HDL2 - Meeting Stile Adapter**

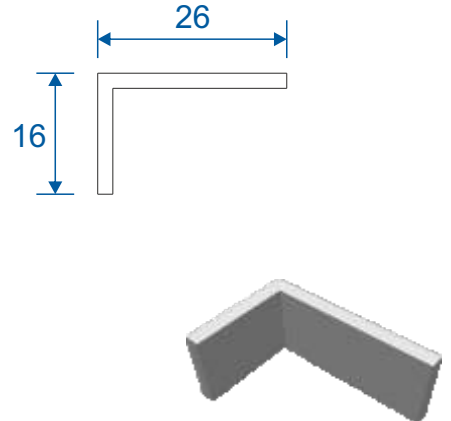

# Top & Bottom Sections And 2 Pane Slider

## Head

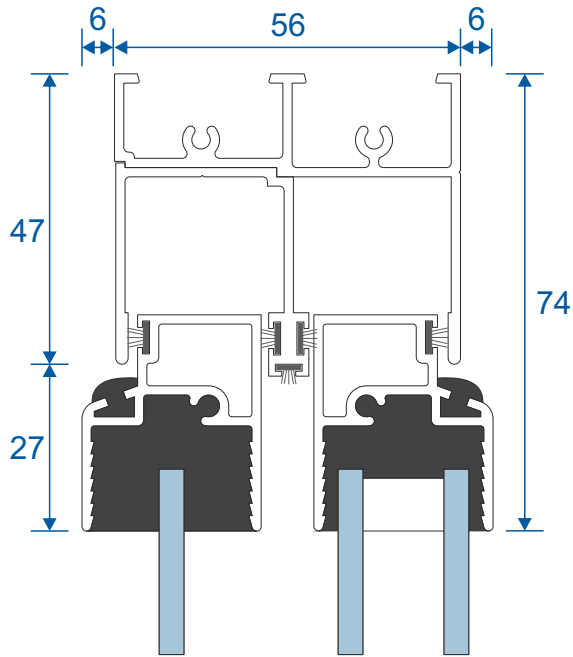

## Base

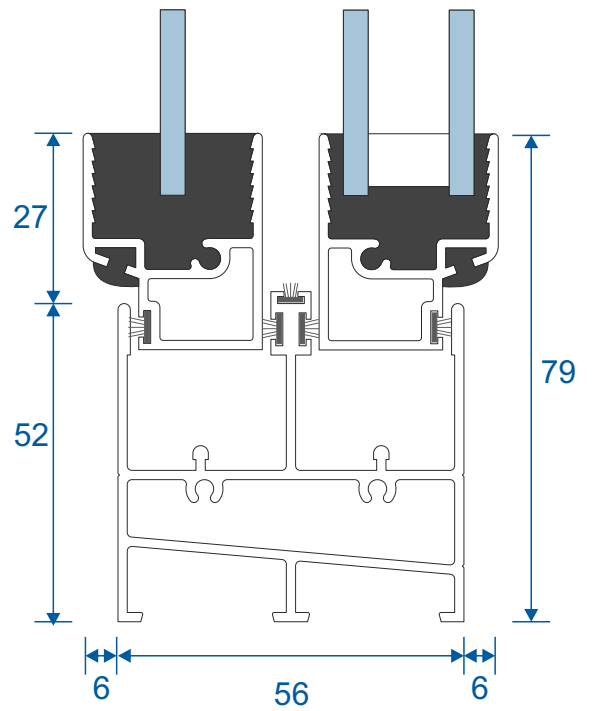

## 2 Pane Slider - All Panels Moving

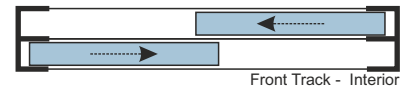

### Prime Windows Side

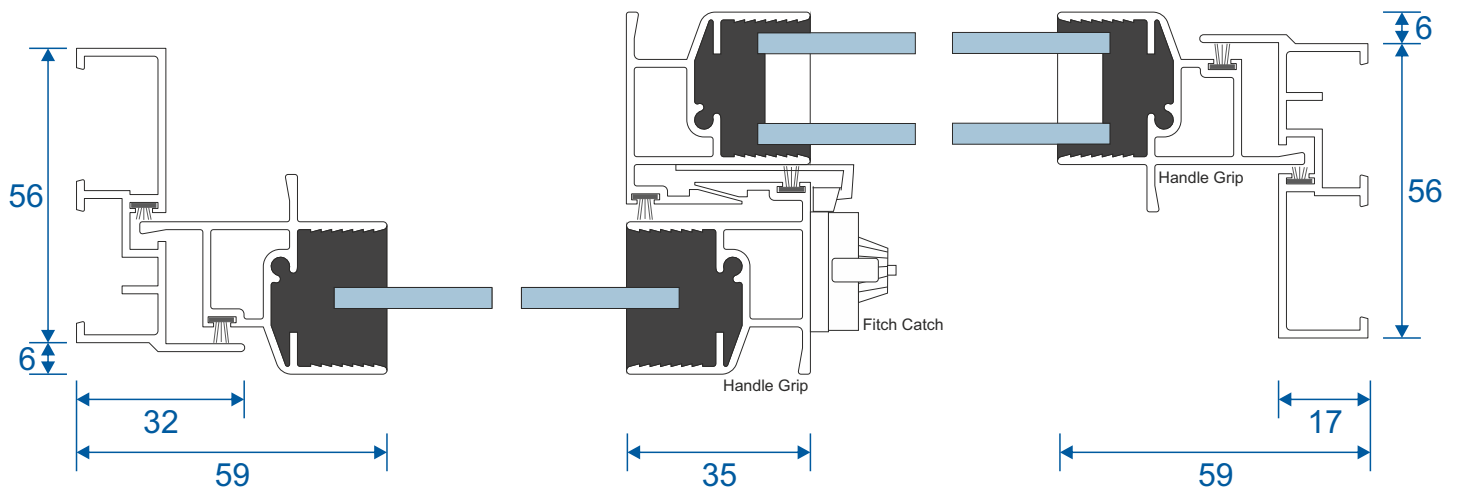

### Interior Room Side

# 3 Pane Sliders

## 3 Pane - Middle Fixed

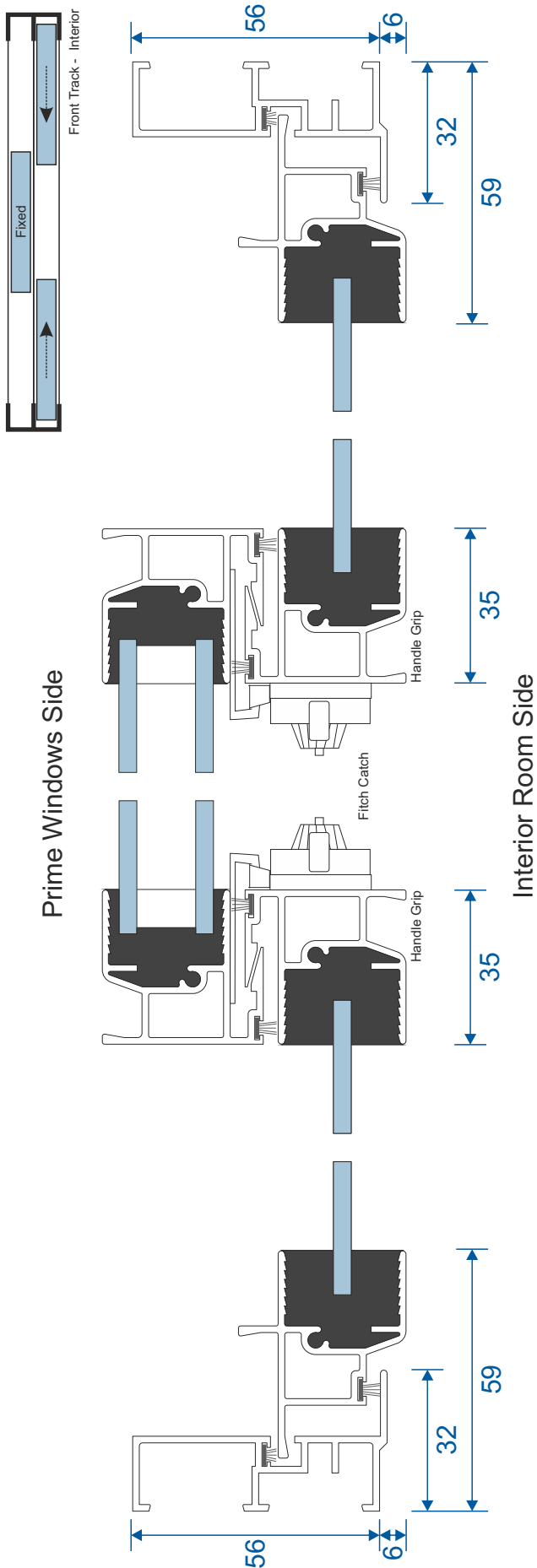

## 3 Pane - All Moving

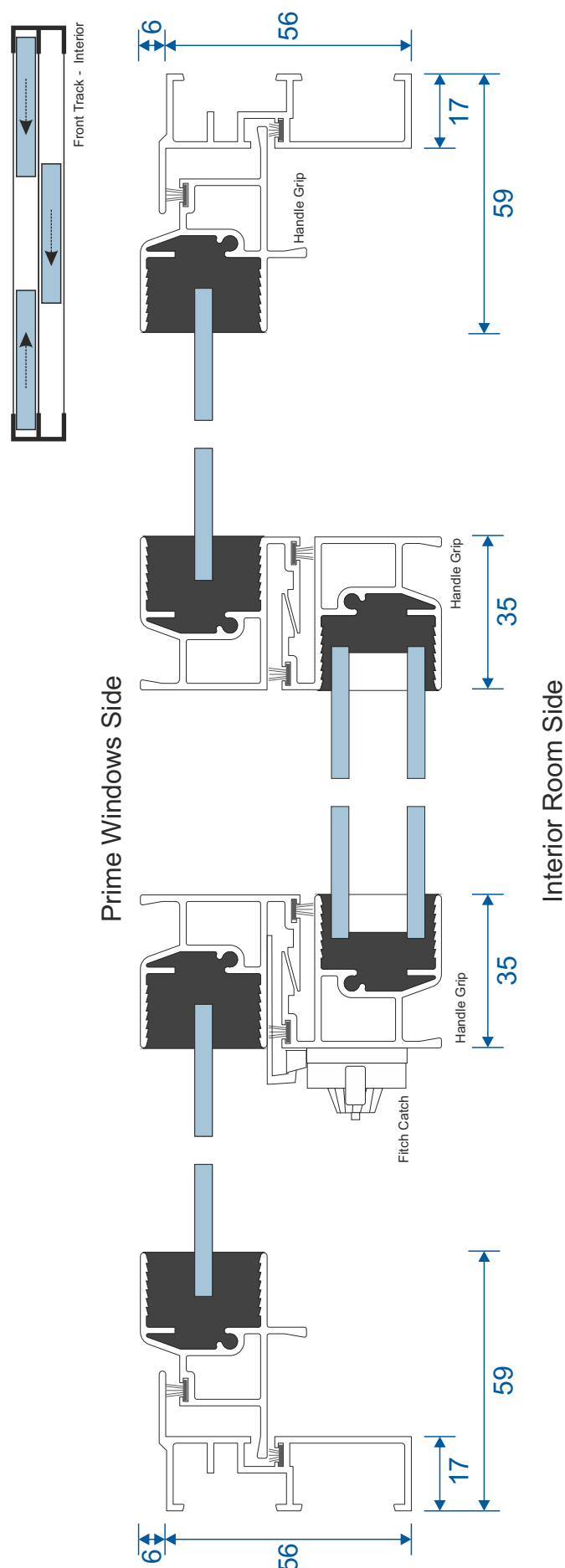

# 4 Pane Slider

All Moving

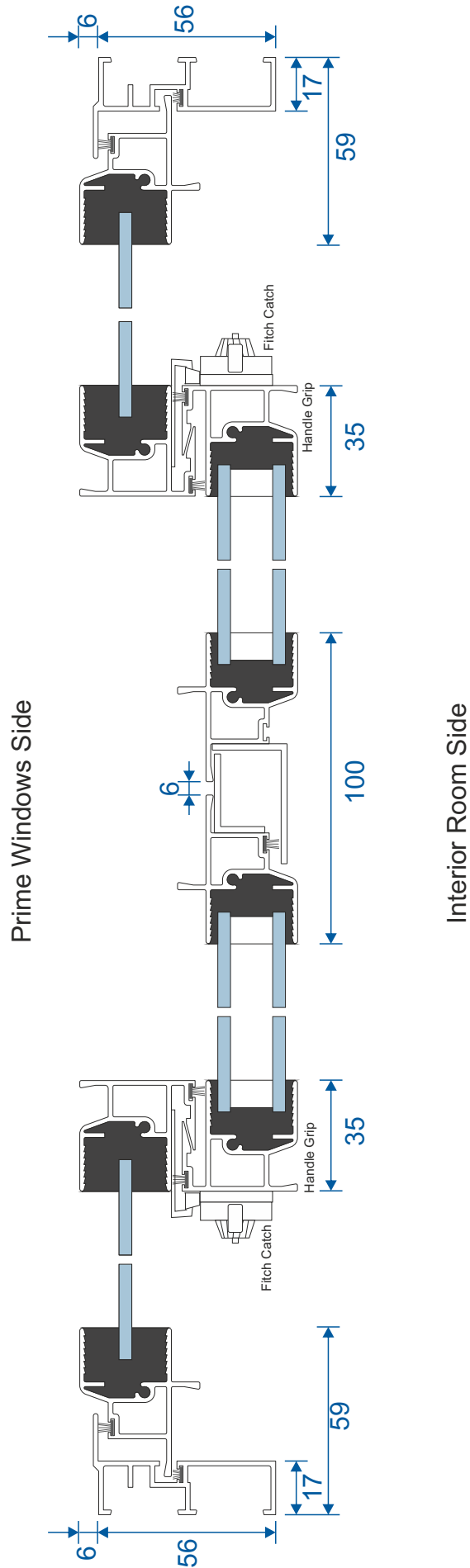
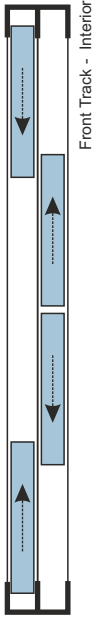

Duration Windows  
Thames Development  
Charfleets Road  
Canvey Island  
Essex. SS8 0PQ

[sales@duration.co.uk](mailto:sales@duration.co.uk)  
[www.duration.co.uk](http://www.duration.co.uk)

**Head Office** 01268 681612  
**Showroom** 01268 695100